

# Shot Controller

312878A

***For use with non-flammable polyurethane foams. Not for use in explosive atmospheres.***

*2000 psi (13.8 MPa, 138 bar) Maximum Working Pressure*



**Important Safety Instructions**

Read all warnings and instructions in this manual and hydraulic proportioner manual 312062. Save these instructions.

See page 2 for model information.

*Proportioner shown includes Shot Controller, proportioner also available without Shot Controller*

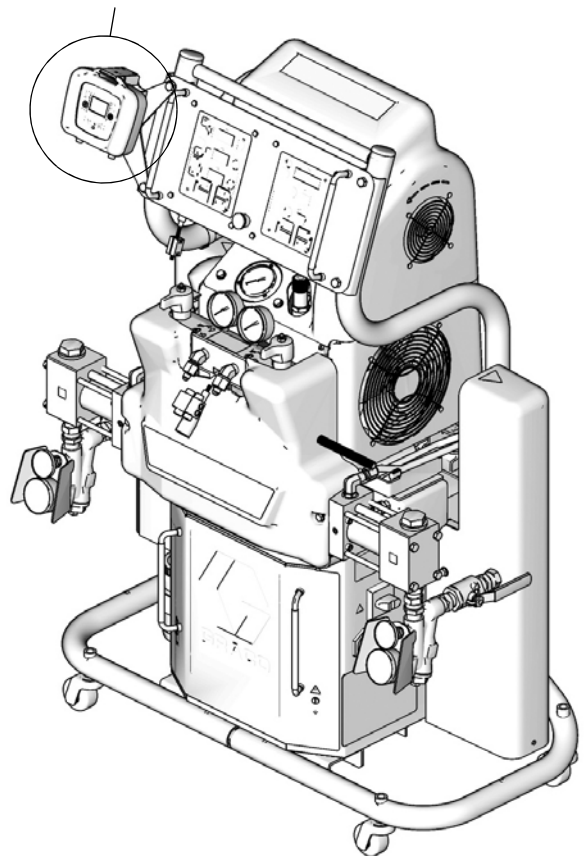

ti11756a

# Contents

**Related Manuals** ..... 2

**Models** ..... 2

**Warnings** ..... 3

**Isocyanate Hazard** ..... 5

**Material Self-ignition** ..... 5

**Moisture Sensitivity of Isocyanates** ..... 5

**Keep Components A and B Separate** ..... 5

**Foam Resins with 245 fa Blowing Agents** ..... 5

**Changing Materials** ..... 5

**Component Identification** ..... 6

**Conversion Kit Installation** ..... 12

**Setup** ..... 17

**Operation** ..... 25

**Pressure Relief Procedure** ..... 27

**Troubleshooting** ..... 29

**Parts** ..... 30

**Technical Data** ..... 33

**Graco Standard Warranty** ..... 34

**Graco Information** ..... 34

# Related Manuals

These manuals can be found at [www.graco.com](http://www.graco.com).

Hydraulic Proportioner	
Part	Description
312062	Hydraulic Reactor Operation Manual
312063	Hydraulic Reactor Repair Manual
Gun	
Part	Description
312888	AR Pour Gun
Pumps	
312068	Proportioning Pumps

# Models

## IPH-25 SERIES

Part, Series	Full Load Peak Amps* Per Phase	Voltage (phase)	System Watts	Primary Heater Watts	Max Flow Rate◆ lb/min (kg/min)	Approximate Output per Cycle (A+B) gal. (liter)	Hydraulic Pressure Ratio	Maximum Fluid Working Pressure psi (MPa, bar)
255814, A	69	230V (1)	15960	8000	22 (10)	0.063 (0.24)	1.91:1	2000 (13.8, 138)
255815, A	46	230V (3)	15960	8000	22 (10)	0.063 (0.24)	1.91:1	2000 (13.8, 138)
255816, A	35	400V (3)	15960	8000	22 (10)	0.063 (0.24)	1.91:1	2000 (13.8, 138)

## IPH-40 SERIES

Part, Series	Full Load Peak Amps* Per Phase	Voltage (phase)	System Watts	Primary Heater Watts	Max Flow Rate◆ lb/min (kg/min)	Approximate Output per Cycle (A+B) gal. (liter)	Hydraulic Pressure Ratio	Maximum Fluid Working Pressure psi (MPa, bar)
255811, A	100	230V (1)	23100	12000	50 (23)	0.076 (0.29)	1.64:1	2000 (13.8, 138)
255812, A	71	230V (3)	26600	15300	50 (23)	0.076 (0.29)	1.64:1	2000 (13.8, 138)
255813, A	41	400V (3)	26600	15300	50 (23)	0.076 (0.29)	1.64:1	2000 (13.8, 138)

## CONVERSION KIT





Part, Series	Description
24A024, A	Conversion kit for existing H-25 and H-40 hydraulic proportioners







\* Full load amps with all devices operating at maximum capabilities. Fuse requirements at various flow rates and mix chamber sizes may be less.

◆ Maximum flow rate given for 60 Hz operation. For 50 Hz operation, maximum flow rate is 5/6 of 60 Hz maximum flow.





# Warnings

The following warnings are for the setup, use, grounding, maintenance, and repair of this equipment. The exclamation point symbol alerts you to a general warning and the hazard symbol refers to procedure-specific risk. Refer back to these warnings. Additional, product-specific warnings may be found throughout the body of this manual where applicable.

 <b>WARNING</b>	
	<p><b>TOXIC FLUID OR FUMES HAZARD</b></p> <p>Toxic fluids or fumes can cause serious injury or death if splashed in the eyes or on skin, inhaled, or swallowed.</p> <ul style="list-style-type: none"> <li>• Read MSDS's to know the specific hazards of the fluids you are using.</li> <li>• Store hazardous fluid in approved containers, and dispose of it according to applicable guidelines.</li> <li>• Always wear impervious gloves when spraying or cleaning equipment.</li> </ul>
	<p><b>PERSONAL PROTECTIVE EQUIPMENT</b></p> <p>You must wear appropriate protective equipment when operating, servicing, or when in the operating area of the equipment to help protect you from serious injury, including eye injury, inhalation of toxic fumes, burns, and hearing loss. This equipment includes but is not limited to:</p> <ul style="list-style-type: none"> <li>• Protective eyewear</li> <li>• Clothing and respirator as recommended by the fluid and solvent manufacturer</li> <li>• Gloves</li> <li>• Hearing protection</li> </ul>
	<p><b>SKIN INJECTION HAZARD</b></p> <p>High-pressure fluid from dispense valve, hose leaks, or ruptured components will pierce skin. This may look like just a cut, but it is a serious injury that can result in amputation. <b>Get immediate surgical treatment.</b></p> <ul style="list-style-type: none"> <li>• Do not point dispense valve at anyone or at any part of the body.</li> <li>• Do not put your hand over the end of the dispense nozzle.</li> <li>• Do not stop or deflect leaks with your hand, body, glove, or rag.</li> <li>• Follow <b>Pressure Relief Procedure</b> in this manual, when you stop spraying and before cleaning, checking, or servicing equipment.</li> <li>• Tighten all fluid connections before operating the equipment.</li> <li>• Check hoses, tubes and couplings daily. Replace worn or damaged parts immediately.</li> </ul>
	<p><b>FIRE AND EXPLOSION HAZARD</b></p> <p>Flammable fumes, such as solvent and paint fumes, in work area can ignite or explode. To help prevent fire and explosion:</p> <ul style="list-style-type: none"> <li>• Use and clean equipment only in well ventilated area.</li> <li>• Eliminate all ignition sources; such as pilot lights, cigarettes, portable electric lamps, and plastic drop cloths (potential static arc).</li> <li>• Keep work area free of debris, including solvent, rags and gasoline.</li> <li>• Do not plug or unplug power cords or turn lights on or off when flammable fumes are present.</li> <li>• Ground equipment, personnel, object being sprayed, and conductive objects in work area. See <b>Grounding</b> instructions.</li> <li>• Use only Graco grounded hoses.</li> <li>• Check gun resistance daily.</li> <li>• If there is static sparking or you feel a shock, <b>stop operation immediately</b>. Do not use equipment until you identify and correct the problem.</li> <li>• Do not flush with gun electrostatics on. Do not turn on electrostatics until all solvent is removed from system.</li> <li>• Keep a working fire extinguisher in the work area.</li> </ul>

 <b>WARNING</b>	
	<p><b>ELECTRIC SHOCK HAZARD</b></p> <p>Improper grounding, setup, or usage of the system can cause electric shock.</p> <ul style="list-style-type: none"> <li>• Turn off and disconnect power at main switch before disconnecting any cables and before servicing equipment.</li> <li>• Connect only to grounded power source.</li> <li>• All electrical wiring must be done by a qualified electrician and comply with all local codes and regulations.</li> </ul>
	<p><b>PRESSURIZED ALUMINUM PARTS HAZARD</b></p> <p>Do not use 1,1,1-trichloroethane, methylene chloride, other halogenated hydrocarbon solvents or fluids containing such solvents in pressurized aluminum equipment. Such use can cause serious chemical reaction and equipment rupture, and result in death, serious injury, and property damage.</p>
	<p><b>EQUIPMENT MISUSE HAZARD</b></p> <p>Misuse can cause death or serious injury.</p> <ul style="list-style-type: none"> <li>• Do not operate the unit when fatigued or under the influence of drugs or alcohol.</li> <li>• Do not exceed the maximum working pressure or temperature rating of the lowest rated system component. See <b>Technical Data</b> in all equipment manuals.</li> <li>• Use fluids and solvents that are compatible with equipment wetted parts. See <b>Technical Data</b> in all equipment manuals. Read fluid and solvent manufacturer's warnings. For complete information about your material, request MSDS forms from distributor or retailer.</li> <li>• Check equipment daily. Repair or replace worn or damaged parts immediately with genuine manufacturer's replacement parts only.</li> <li>• Do not alter or modify equipment.</li> <li>• Use equipment only for its intended purpose. Call your distributor for information.</li> <li>• Route hoses and cables away from traffic areas, sharp edges, moving parts, and hot surfaces.</li> <li>• Do not kink or over bend hoses or use hoses to pull equipment.</li> <li>• Keep children and animals away from work area.</li> <li>• Comply with all applicable safety regulations.</li> </ul>
	<p><b>MOVING PARTS HAZARD</b></p> <p>Moving parts can pinch or amputate fingers and other body parts.</p> <ul style="list-style-type: none"> <li>• Keep clear of moving parts.</li> <li>• Do not operate equipment with protective guards or covers removed.</li> <li>• Pressurized equipment can start without warning. Before checking, moving, or servicing equipment, follow the <b>Pressure Relief Procedure</b> in this manual. Disconnect power or air supply.</li> </ul>
	<p><b>BURN HAZARD</b></p> <p>Equipment surfaces and fluid that's heated can become very hot during operation. To avoid severe burns, do not touch hot fluid or equipment. Wait until equipment/fluid has cooled completely.</p>

## Isocyanate Hazard

						
---	---	---	---	---	--	--



Spraying materials containing isocyanates creates potentially harmful mists, vapors, and atomized particulates.

Read material manufacturer's warnings and material MSDS to know specific hazards and precautions related to isocyanates.

Prevent inhalation of isocyanate mists, vapors, and atomized particulates by providing sufficient ventilation in the work area. If sufficient ventilation is not available, a supplied-air respirator is required for everyone in the work area.

To prevent contact with isocyanates, appropriate personal protective equipment, including chemically impermeable gloves, boots, aprons, and goggles, is also required for everyone in the work area.

## Material Self-ignition

						
---	---	--	--	--	--	--

Some materials may become self-igniting if applied too thickly. Read material manufacturer's warnings and material MSDS.

## Moisture Sensitivity of Isocyanates

Isocyanates (ISO) are catalysts used in two component foam and polyurea coatings. ISO will react with moisture (such as humidity) to form small, hard, abrasive crystals, which become suspended in the fluid. Eventually a film will form on the surface and the ISO will begin to gel, increasing in viscosity. If used, this partially cured ISO will reduce performance and the life of all wetted parts.

 The amount of film formation and rate of crystallization varies depending on the blend of ISO, the humidity, and the temperature.

To prevent exposing ISO to moisture:

- Always use a sealed container with a desiccant dryer in the vent, or a nitrogen atmosphere. **Never** store ISO in an open container.

- Keep the ISO lube pump reservoir (if installed) filled with Graco Throat Seal Liquid (TSL), Part 206995. The lubricant creates a barrier between the ISO and the atmosphere.
- Use moisture-proof hoses specifically designed for ISO, such as those supplied with your system.
- Never use reclaimed solvents, which may contain moisture. Always keep solvent containers closed when not in use.
- Never use solvent on one side if it has been contaminated from the other side.
- Always lubricate threaded parts with ISO pump oil or grease when reassembling.

## Keep Components A and B Separate

CAUTION
To prevent cross-contamination of the equipment's wetted parts, <b>never</b> interchange component A (isocyanate) and component B (resin) parts.

## Foam Resins with 245 fa Blowing Agents

New foam blowing agents will froth at temperatures above 90°F (33°C) when not under pressure, especially if agitated. To reduce frothing, minimize preheating in a circulation system.

## Changing Materials

- When changing materials, flush the equipment multiple times to ensure it is thoroughly clean.
- Always clean the fluid inlet strainers after flushing.
- Check with your material manufacturer for chemical compatibility.
- Most materials use ISO on the A side, but some use ISO on the B side.
- Epoxies often have amines on the B (hardener) side. Polyureas often have amines on the B (resin) side.

# Component Identification

## IPH System

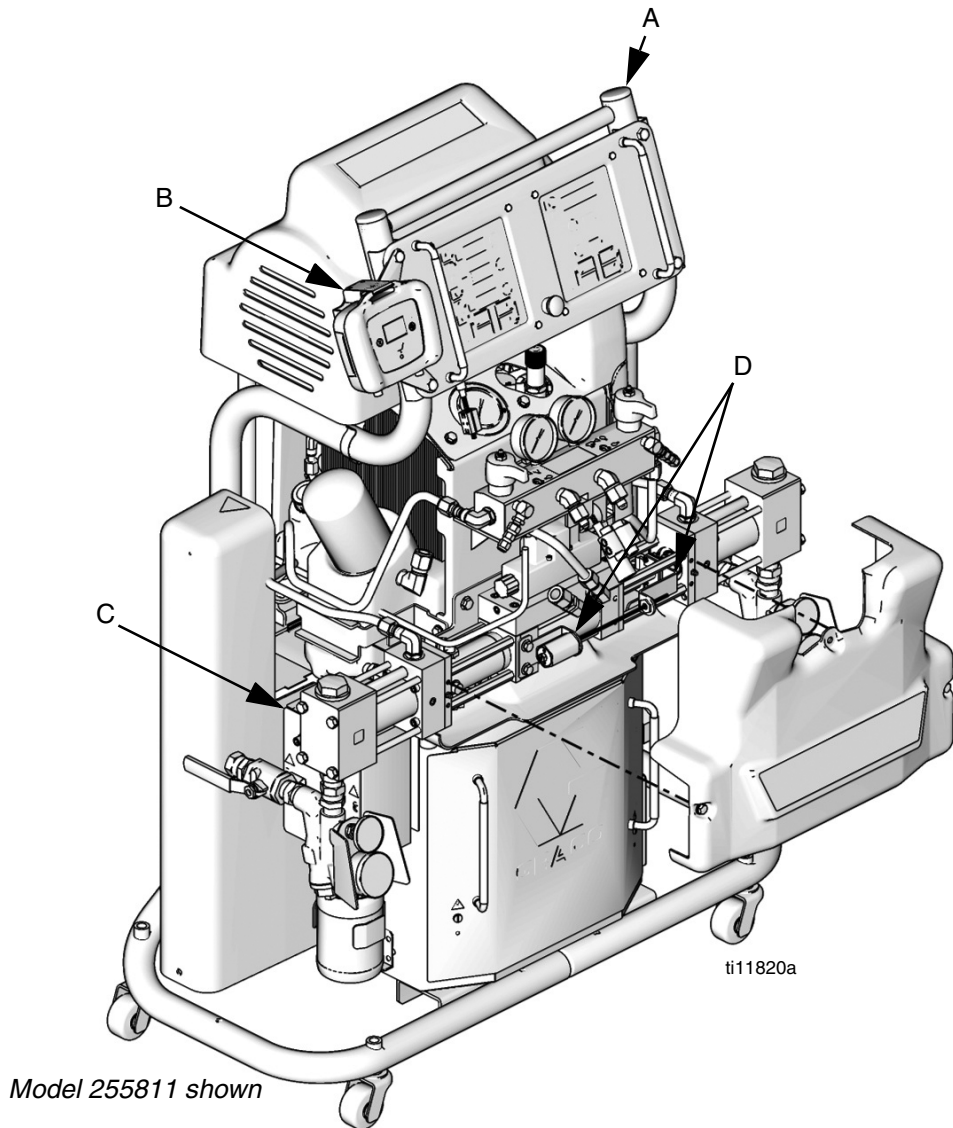
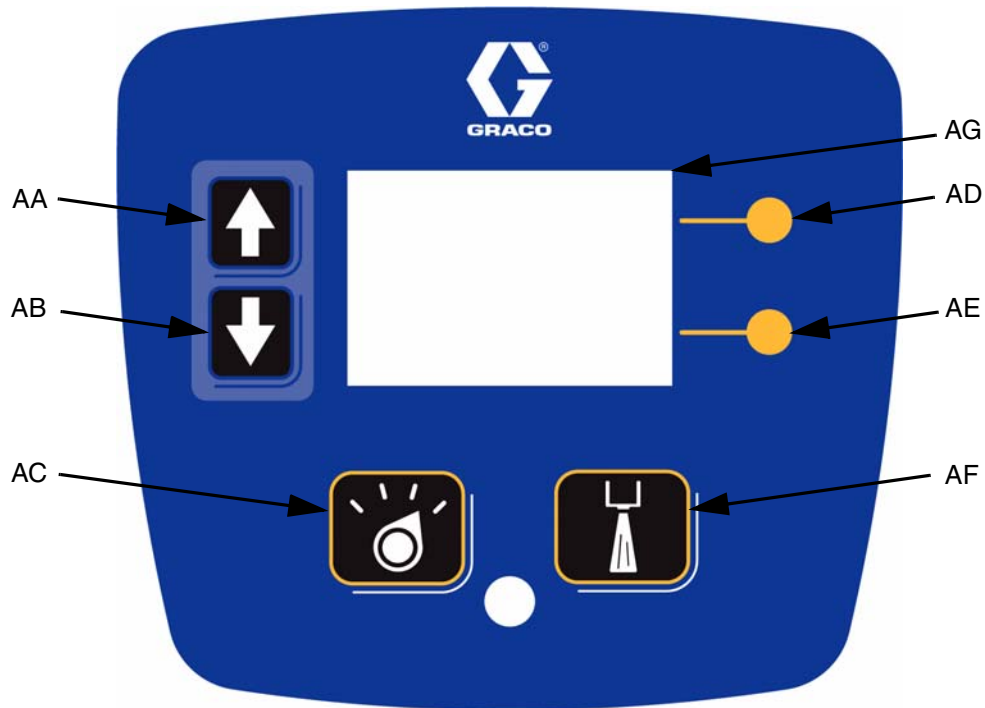

**Fig. 1: IPH System with Front Cover Removed**

**Key:**

- A Hydraulic Proportioner
- B Shot Controller, HMI, and Bracket
- C Electrical Enclosure
- D Linear Sensor Assembly

## Human Machine Interface (HMI)



**FIG. 2**

**Key:**

AA Up arrow key  
 AB Down arrow key  
 AC Mode select button  
 AD Top soft key

AE Bottom soft key  
 AF Initiate shot button  
 AG LCD screen

**Initiate Shot button**

Pressing this button will start a shot for either the selected shot number, the next shot number in the selected sequence, or when in manual mode will dispense until the user releases the button.

















This button is initially set as disabled and can be enabled or disabled from setup screen #7. See **Setup Screen #7: Enable/Disable Run Screen Shot Editing** or **“Initiate Shot” button** on page 18.

**Mode Select button**



Pressing this button will allow selection of an operating mode. The available choices will always include Shot, “Sh,” and Manual, “Mn”.

If one or more sequences have been programmed, the Sequence modes available will show up as the name of each sequence (“Sq-A,” “Sq-B,” etc.).

## Icons

Icon	Function	Shown on Screen(s)
<b>General Icons</b>		
	Confirm changes	<ul style="list-style-type: none"> <li>All</li> </ul>
	Exit without saving changes	<ul style="list-style-type: none"> <li>All</li> </ul>
	Next	<ul style="list-style-type: none"> <li>Setup screen #1</li> <li>Setup screen #3</li> <li>Run screen when Learn Mode is enabled</li> </ul>
	Previous	<ul style="list-style-type: none"> <li>Setup screen #1</li> <li>Run screen when Learn Mode is enabled</li> </ul>
	Learn Mode Active Indicator (shown in lower-left corner)	<ul style="list-style-type: none"> <li>Run screen when Learn Mode is enabled</li> </ul>
<b>Setup Icons - see Controller Setup section on page 17</b>		
	Reset Piston Counter to Zero	<ul style="list-style-type: none"> <li>Setup screen #1</li> </ul>
	Define Shot Amount	<ul style="list-style-type: none"> <li>Setup screen #2</li> </ul>
	Define Sequence Modes	<ul style="list-style-type: none"> <li>Setup screen #3</li> </ul>
	Open Gun Dispense Valve	<ul style="list-style-type: none"> <li>Setup screen #4</li> </ul>
	Close Gun Dispense Valve	<ul style="list-style-type: none"> <li>Setup screen #4</li> </ul>
	Change Password	<ul style="list-style-type: none"> <li>Setup screen #5</li> </ul>
	Enable "Tap" mode	<ul style="list-style-type: none"> <li>Setup screen #6</li> </ul>
	Enable "Hold" mode	<ul style="list-style-type: none"> <li>Setup screen #6</li> </ul>
	Enable "Initiate Shot" button on HMI	<ul style="list-style-type: none"> <li>Setup screen #7</li> </ul>
	Disable "Initiate Shot" button on HMI	<ul style="list-style-type: none"> <li>Setup screen #7</li> </ul>
	Enable Run Screen Shot Editing	<ul style="list-style-type: none"> <li>Setup screen #7</li> </ul>



Icon	Function	Shown on Screen(s)
	Disable Run Screen Shot Editing	<ul style="list-style-type: none"> <li>• Setup screen #7</li> </ul>
	Enter Learn Mode	<ul style="list-style-type: none"> <li>• Setup screen #8</li> </ul>
	Exit Learn Mode	<ul style="list-style-type: none"> <li>• Setup screen #8</li> </ul>

## Run Screen

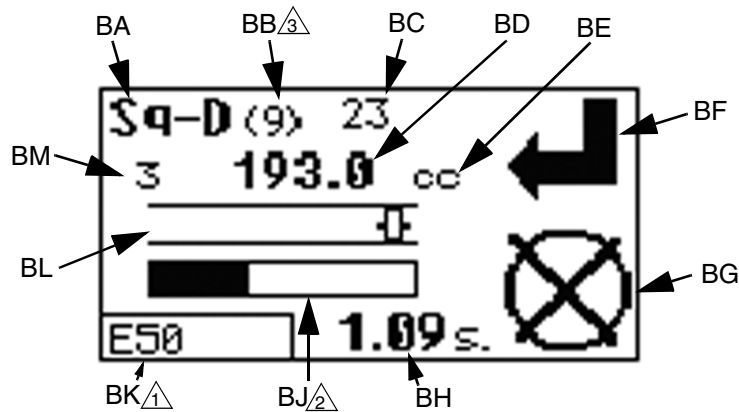

- △<sub>1</sub> When no errors are active, "E" will be displayed.
- △<sub>2</sub> Shown only during shot dispensing in Shot or Sequence mode
- △<sub>3</sub> Displayed only in Sequence mode

### Key:

- BA Current operating mode
- BB  $n^{th}$  shot in sequence
- BC Number of shots executed for selected shot number
- BD Quantity of selected shot (Shot or Sequence modes) or previous shot (Manual mode)
- BE Quantity unit of measure (cubic centimeters or grams)
- BF Top soft key icon
- BG Bottom soft key icon
- BH Duration of selected shot (Shot or Sequence modes) or previous shot (Manual mode)
- BJ Progress bar for current shot
- BK Error status
- BL Piston position
- BM Shot number currently selected

FIG. 3: Run Screen

## Run Screen Variables

Available operating modes vary by setup but will include "Sh" for predefined shot mode and "Mn" for manual shot mode. If sequences have been defined, operating mode options will include "Sq-A", "Sq-B", etc. to select any of the defined sequences. See **Change Operating Mode** on page 25.

Shot quantity can be displayed either in cubic centimeters or grams depending on whether specific gravity is entered. See **Setup Screen #6: Quantity Units and Gun Configuration** on page 18.

The top and bottom soft key icons indicate the function of the respective soft key. See **Icons** section on page 8 for icon descriptions.

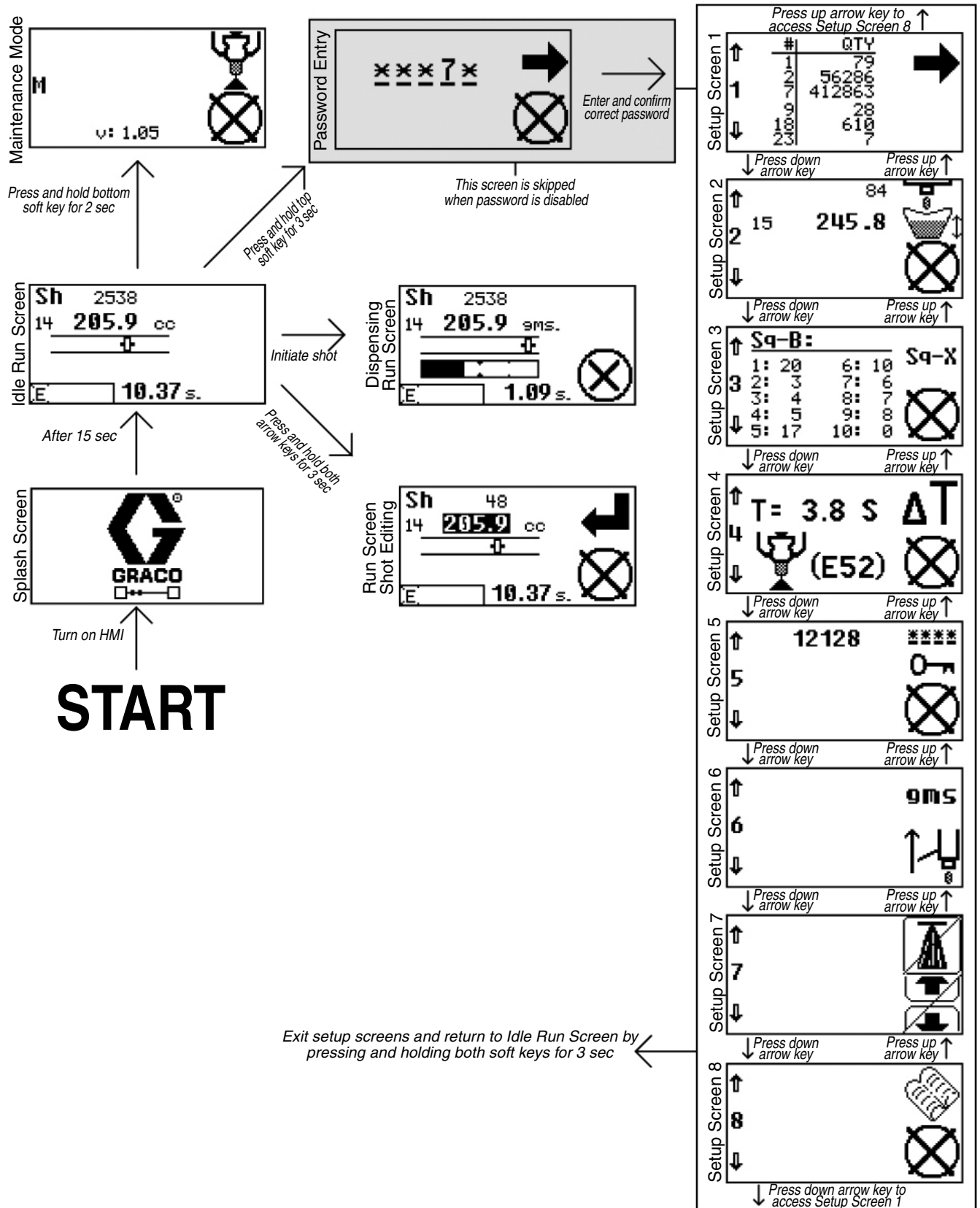



FIG. 4: Screen Navigation Diagram

## Conversion Kit Installation

 The IPH-25 and IPH-40 systems include a hydraulic proportioner and conversion kit 24A024 and are assembled at the factory.

These instructions are for installing Conversion Kit 24A024 onto an existing H-25 or H-40 hydraulic proportioner.

See **Parts** on page 30 for Conversion Kit 24A024 parts.

### Install New Reversing Switch Activator Plate

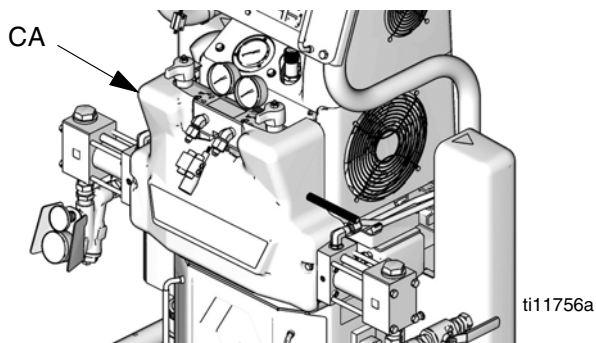

**FIG. 5**

1. Remove front cover (CA).

 For steps 2 through 4, refer to Proportioning Pump manual 312068 for detailed instructions.

2. Remove right clevis 261503 and reversing switch activator plate.
3. Install new reversing switching activator plate (21).
4. Replace right clevis 261503.

## Install Linear Sensor

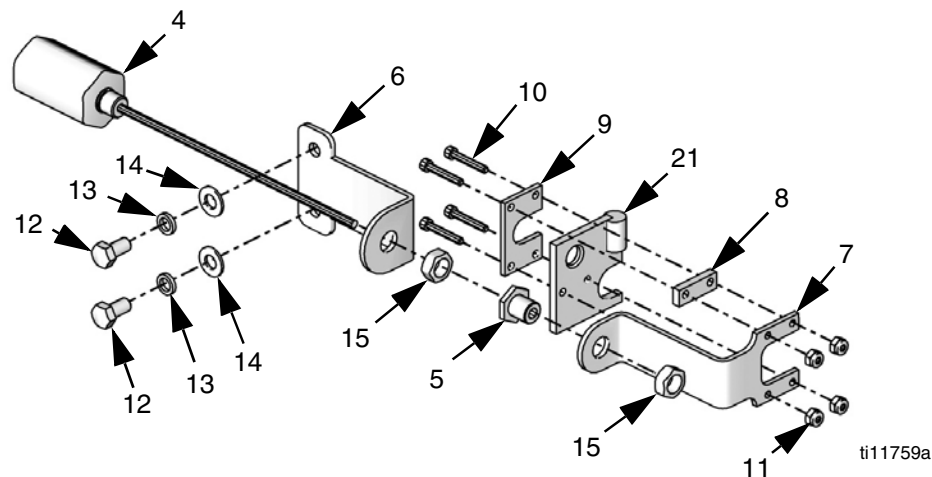
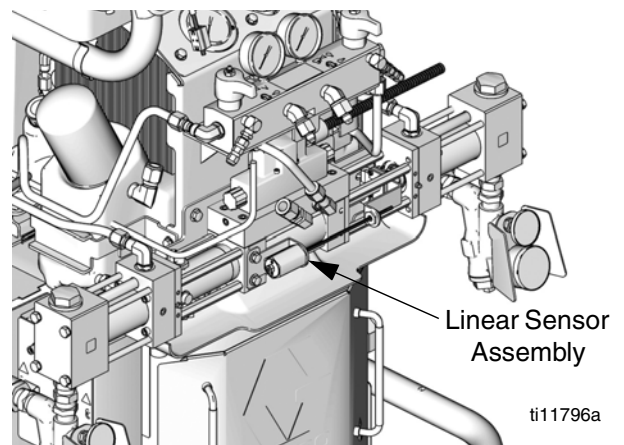

**FIG. 6**

5. Place the magnet bracket plate (9) on the left side of the activator plate (21).
6. Pass two socket head cap screws (10) through the bottom two holes of magnet bracket plate (9) and activator plate (21).
7. Place the magnet bracket spacer (8) on top of the activator plate (21).

 The holes in the magnet bracket spacer (8) are off-center. Make sure the side with more space between the edge and holes faces down.

8. Pass the remaining two socket head cap screws (10) through the top two holes of magnet bracket plate (9) and the two holes in magnet bracket spacer (8).
9. Place the magnet mounting bracket (7) on the right side of the activator plate (21), guiding the four socket head cap screws (10) through the four holes in the bracket.
10. Spin the four lock nuts (11) onto the ends of the four socket head cap screws (10) and tighten.
11. Apply thread sealant to threads of magnet holder (5).
12. Attach magnet holder (5) to the end of the magnet mounting bracket (7) using nut (15).



**FIG. 7: Assembled View with Front Cover Removed**

13. Attach linear sensor bracket (6) to the left hydraulic cylinder port block using two hex head cap screws (12), flat washers (14), and split lock washers (13).
14. Apply thread sealant to remaining nut (15)
15. Install linear sensor (4) in the linear sensor bracket (6) using remaining nut (15).
16. Pass wiring harness from linear sensor (4) through opening in top of electrical cabinet (DE).
17. Replace front cover (CA).

## Install Electrical Enclosure

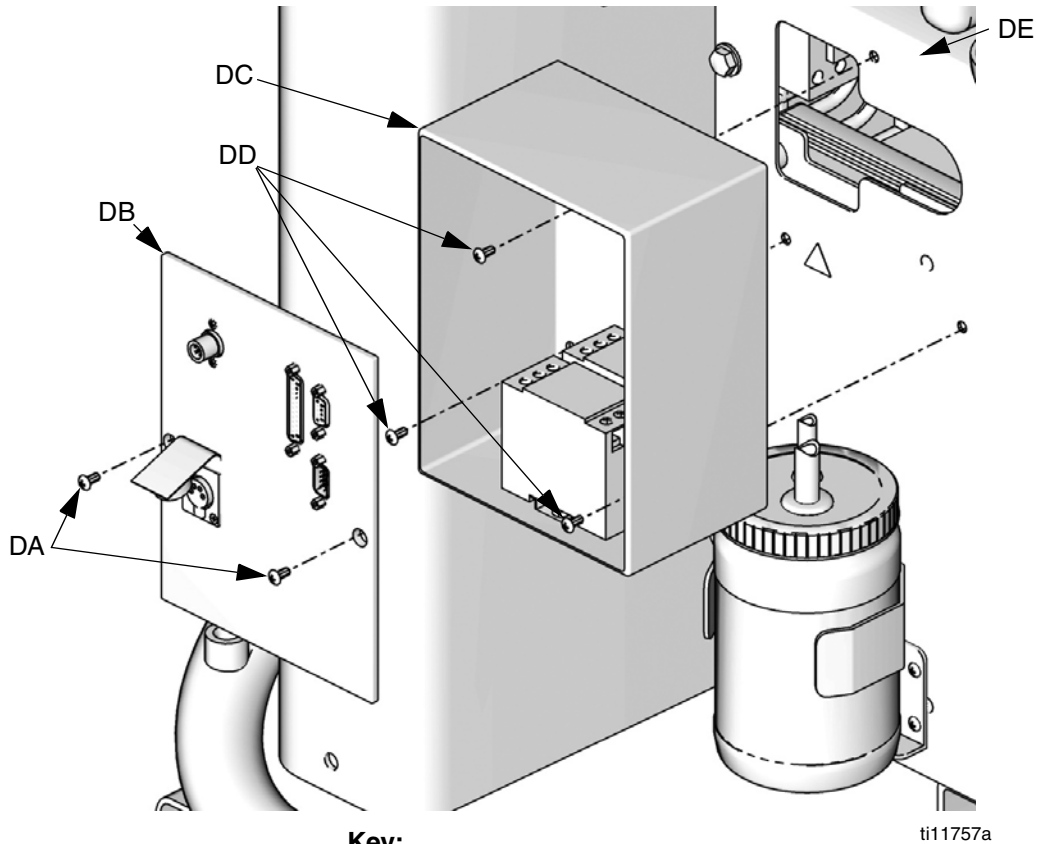

- Key:**  
DA Screw  
DB Electrical enclosure cover  
DC Electrical enclosure  
DD Wire access cover screws  
DE Electrical cabinet

**FIG. 8**

18. Remove three screws (DD) holding wire access cover to the electrical cabinet.
19. Remove wire access cover from the left side of the electrical cabinet (DF). The wire access cover will not be re-used.
20. Remove electrical enclosure cover (DB) from the electrical enclosure (DC) by removing two screws (DA).
21. Pass wire harness from electrical enclosure cover (DB) through back of electrical enclosure (DC) and into electrical cabinet (DE).
22. Install electrical enclosure (DC) to side of electrical cabinet (DE) using three screws (DD).
23. Install electrical enclosure cover (DB) to electrical enclosure using two screws (DA).

## Install Shot Controller

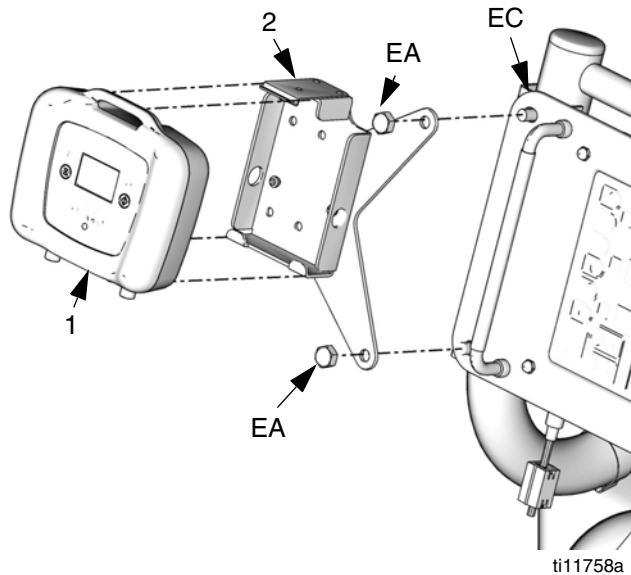
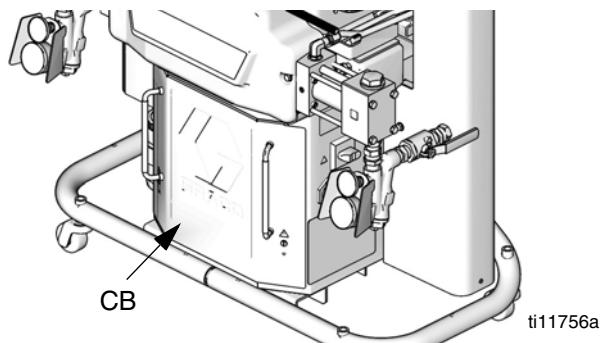

**FIG. 9**

24. Remove the two left side crown nuts (EA) from the display (EC).
25. Apply thread sealant to threads of crown nuts (EA).
26. Install shot controller bracket (2) to display (EC) using crown nuts (EA).
27. Snap shot controller (1) into shot controller bracket (2).

## Connect the Wire Harnesses

 See **Wiring Diagram** on page 16.



**FIG. 10**

28. Remove electrical cabinet front cover (CB).

29. Connect the “pump” plug to J12 on the motor control board.
30. Connect the “temp” plug to the “data” connector on the temperature control board.
31. Connect wire harness to the linear sensor.
32. Connect 3-pin plug to J5 on the motor control board.
33. Connect 5-pin plug to J6 on the motor control board.
34. Connect the two power leads to the fan fuse block.
35. Replace electrical cabinet front cover (CB).

## Connect Shot Controller Cables

 See **Wiring Diagram** on page 16.

36. Plug DB25 data cable 15T859 into the receptacles on the electrical enclosure cover (DB) and the shot controller (1).
37. Plug power cable 121003 into the electrical enclosure cover (DB) and the left receptacle on the shot controller (1).

## Wiring Diagram

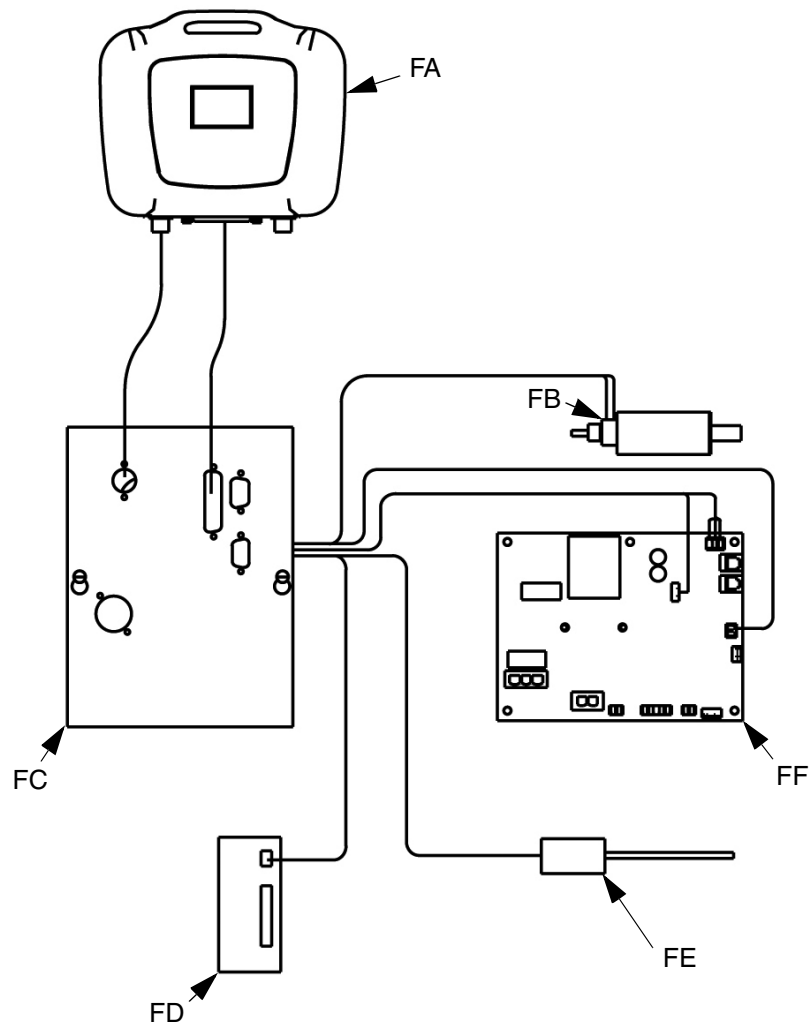

**Key:**

- FA Shot Controller
- FB Hydraulic Proportioner Fan Fuse Block
- FC Electrical Enclosure
- FD Hydraulic Proportioner Temperature Control Board  
(view from front of hydraulic proportioner)
- FE Linear Sensor
- FF Hydraulic Proportioner Motor Control Board

**FIG. 11: H25, H40 Conversion Kit Wiring Diagram**



# Setup

## Hydraulic Proportioner Setup

See hydraulic proportioner manual 312062.

## Controller Setup



When in any of the setup screens, pouring is disabled.

To enter the setup screens, press and hold the top soft key for three seconds. To exit the setup screens, press and hold both soft keys for three seconds. See FIG. 2 on page 7 for HMI button identification.

To navigate between the setup screens, for example from setup screen #1 to setup screen #2, use the up and down arrow keys. To navigate within a setup screen, for example from the first page of setup screen #6 to the second page of setup screen #6, use the soft keys.

See FIG. 4 on page 11 for illustration of the setup screens and navigation.

### Setup Screen #1: System Data

This screen is a collection of system data that includes the shot counter for each programmed shot, total piston stroke counter, and a separate resettable piston stroke counter. The piston stroke counters are displayed on the last screen of setup screen #1.

To restart the counter for the resettable piston stroke counter navigate to setup screen number one. Press the top soft key to navigate to the next data page. Press the top soft key repeatedly until the icon for the bottom soft key is "0." Press the bottom soft key to zero the counter and confirm the selection when prompted.

### Setup Screen #2: Shot Number Definitions



The shot quantity units, cubic centimeters or grams, for which each shot number quantity is defined is dependent on whether the material specific gravity has been entered. See **Setup Screen #6: Quantity Units and Gun Configuration** on page 18.

From setup screen #2, any of the twenty-five available shot numbers can be edited. Each shot number can be defined so that the machine will dispense the input quantity of material when the shot number is selected and a shot is initiated.

To edit a shot number, navigate to setup screen #2. Hit the top soft key then use the arrow keys to highlight a shot number to edit. Hit the top soft key to select and change the quantity for the selected shot using the up and down arrow keys. Hit the top soft key to enter the change then confirm the change when prompted.

### Setup Screen #3: Shot Sequences

Setup screen #3 shows the five customizable shot sequences, each with a sequence of ten shots. Each of the ten shots in each sequence can be changed to any of the shot numbers defined using setup screen #2. If any sequence contains either an undefined shot or one of the positions in the sequence is undefined, that shot will be skipped when operating with that sequence.

To edit a shot sequence, navigate to setup screen #3. Hit the top soft key to move to the next screen then use the up and down arrows to highlight a shot sequence. Press the top soft key to select the highlighted sequence then use the arrow keys to navigate to the  $n^{\text{th}}$  shot in that sequence and hit the top soft key to select. Once selected, use the arrow keys to change the  $n^{\text{th}}$  shot in the sequence to a different shot number. See **Setup Screen #2: Shot Number Definitions**.

## Setup Screen #4: Adjusting E52 Error Delay

 Smaller piston sizes and longer hoses will require a longer delay.

When finished dispensing, the piston will continue to travel slightly before being stopped and if the piston travels longer than expected the E52 error will occur. If the E52 error code is triggered often, the likelihood of the alarm triggering can be lowered by extending the time the machine waits before triggering the alarm.

To edit the E52 error delay, navigate to Setup Screen #4 then press the top soft key to enter editing mode. Use the up and down arrow keys to edit the time then press the top soft key to enter the change.

## Setup Screen #5: Password Protection

See **Password Protection** section on page 19.

## Setup Screen #6: Quantity Units and Gun Configuration

Setup screen #6 serves two functions: toggling between measuring shot quantity in cubic centimeters or grams, and toggling between gun modes “Tap” and “Hold.”

### Quantity Units

To configure the machine to display shot quantity in grams, when it is currently displaying cubic centimeters, navigate to setup screen #6. Press the top soft key then enter the specific gravity of the dispensed and mixed material using the arrow keys. Press the top soft key when finished to confirm.

To configure the machine to display shot sizes in cubic centimeters, when it is currently displaying in grams, navigate to setup screen #6. Press the top soft key then confirm the selection when prompted.



### “Tap” and “Hold” Gun Modes

“Tap” mode and “Hold” mode define how the machine responds to pulling/releasing the gun trigger and, if enabled, pressing/releasing the “Initiate Shot” button on the HMI.





 When in manual mode, the machine will only shoot when the gun trigger or “Initiate Shot” button is held, regardless of which mode, “Tap” or “Hold,” is selected.

In “Tap” mode, signified by the icon , a shot is first initiated by tapping and releasing the gun trigger or “Initiate Shot” button. Once a shot is started, the shot can only be stopped or started again by tapping the trigger or the bottom soft key. The shot will continue until the predefined time elapses or the trigger or bottom soft key is tapped.

In “Hold” mode, signified by the icon , shots are initiated by pulling the gun trigger or pushing the “Initiate Shot” button. Unlike “Tap” mode, the shot will only continue as long as the trigger or button is held. If the trigger or button is held longer than the predefined duration of the selected shot, the shot will end when the predefined duration elapses.

To toggle between “Tap”  and “Hold”  mode, navigate to setup screen #6 and press the top soft key which will have next to it either the “Tap” or “Hold” icon.

## Setup Screen #7: Enable/Disable Run Screen Shot Editing or “Initiate Shot” button

						
<p>Enabling the “Initiate Shot” button allows starting and stopping shots from both the gun and the “Initiate Shot” button. When operating with the “Initiate Shot” button enabled, the gun must be locked in a pouring enclosure so that all dispensed material will be dispensed in a direction away from people.</p>						

 The system is shipped with the “Initiate Shot” button disabled.

To enable or disable Run Screen Shot Editing of the “Initiate Shot” button on the HMI, navigate to setup screen #7 and push the top soft key. Confirm the selection when prompted. See **Icons** section on page 8.

## Setup Screen #8: “Learn” Mode

See **Learn Mode** section on page 20.

## Setup Screen #10: Define Piston Size

See **Piston Size** section on page 21.

## Password Protection

The setup screens can be protected by a password to restrict their accessibility. When the password is “00000,” the setup screens can be accessed without entering a password.

To create a password to protect the setup screens or to change the existing password, navigate to setup screen #5 and hit the top soft key to enter the password entry screen. Enter the new password twice and then hit the top soft key to confirm.

To disable the password, change the password to “00000” as described in the previous paragraph.

To access the setup screens when the password is enabled, press the top soft key for three second and the password entry screen will appear. Enter the password and confirm to access the setup screens.

### Entering a Password

Use the up and down arrow keys to change the selected digit in the password. To move to the next digit, press the top soft key. If a mistake is made, hit the bottom soft key to exit password entry and then re-enter setup mode to enter the password.

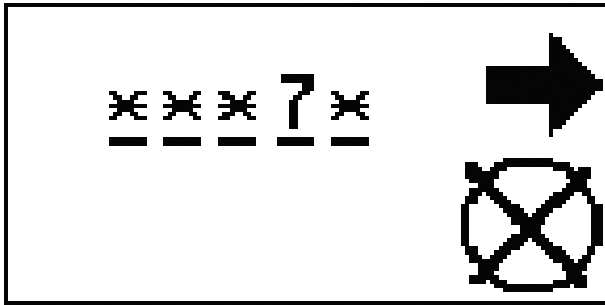

**FIG. 12: Password Entry Screen**

### Resetting Password

If the password is forgotten, the password can be reset without losing the current machine settings or shot data.

1. Remove power from the shot controller for 10 seconds.
2. Reapply power to the shot controller.
3. When the idle run screen appears, immediately press and hold both the top soft key and up arrow key for six seconds. The password will then automatically be reset to “00000.”

## Learn Mode



Learn mode will need to be used following the installation of the conversion kit, the linear sensor or its mounting bracket, or the shot controller.

The IPH units are programmed at the factory so Learn mode will not need to be used prior to pouring.

Learn mode enables the shot controller to learn the left-most and right-most piston positions. To do this, the standard piston controls are disabled and the piston is moved left and right using the top soft key. With Learn mode enabled the top soft key icon will be a left or right arrow to signify the direction the piston will move when pressed. In the usual bottom soft key icon location, the left-most and right-most piston positions obtained from using Learn mode will be shown.

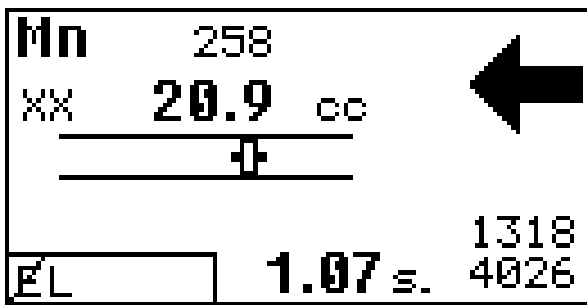

FIG. 13: Run Screen with Learn Mode Enabled

## Learn Piston Left-most and Right-most Positions

### Enable Learn Mode

1. Change the operating mode to Manual, see **Change Operating Mode** section on page 25.
2. Navigate to setup screen #8. See FIG. 4 on page 11.
3. Select the top soft key with the “Enter Learn Mode” icon and confirm the selection when prompted. See **Icons** section on page 8.
4. Press and hold both the top and bottom soft keys for three seconds to exit the setup screens.

### Obtain Piston Range Information

To view the physical piston movement, remove the front cover (CA) from the machine. Replace the cover when finished using Learn mode.

5. Using a bucket to catch the dispensed material, trigger the gun until the piston reaches the left-most or right-most position.
6. Manually reverse piston direction by pressing the top soft key.
7. Repeat steps 5 and 6 until the piston range displayed in the bottom right corner of the screen remains constant.

If the piston range displayed in the bottom right corner of the screen contains a number outside the range of 200 to 4650, error code E50 will be generated. A number outside this range means that either the linear position sensor is not properly installed or there is a problem with the shot controller electronics. Error code E50 will be generated until the problem is corrected.

### Disable Learn Mode

8. Navigate to setup screen #8.
9. Press the soft key adjacent to the “Disable Learn Mode” icon. Confirm the selection when prompted.
10. Exit setup mode by pressing and holding both soft keys for three seconds.

## Piston Size

 If the system is off-ratio with a B side piston size different from the A side piston, the impingers in the gun may need to be adjusted to achieve equal pressures in the A and B side chemical lines. For impinger adjustment procedure for the AR Pour Gun, see manual 312888 available at [www.graco.com](http://www.graco.com).

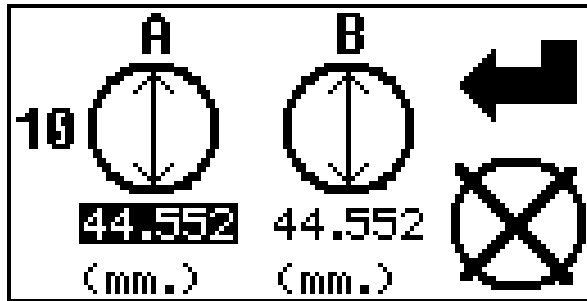

Size	Pump	Diameter (mm)
30	247371	22.225
40	247372	25.629
48	247373	28.092
60	247374	31.496
80	247375	36.297
88	247577	38.024
96	247376	39.802
120	247377	44.552
140	247576	47.955

## Define Piston Size

 If piston diameter editing is aborted prior to confirming the entry of both piston diameters, no changes will be saved.

1. Remove then re-supply power to the shot controller.
2. Within 20 seconds of the Idle Run Screen appearing, press and hold both the top soft key and the down arrow key for six seconds.
3. When prompted, enter password "88888." See **Password Protection** section on page 19.
4. Edit the "A" side piston diameter using the up and down arrow keys and the information provided in the preceding table.
5. Press the top soft key to edit the "B" side piston diameter.
6. Edit the "B" side piston diameter using the up and down keys and the information provided in the preceding table.
7. Press the top soft key to confirm the piston entries. The shot controller will then return to the idle run screen.

## Optional External Machine Control

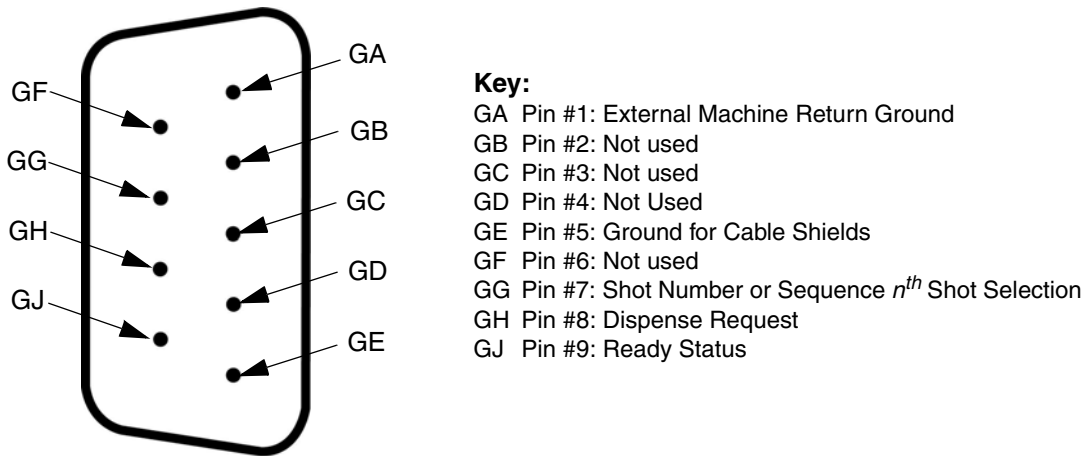

FIG. 14: DB9 Male Connector on Electrical Enclosure

All electrical work must be done by a technician knowledgeable in electronics.						

<b>CAUTION</b>
The external machine must use a semi-conductor based output, such as an NPN transistor.

An optional external machine control interface can be installed if desired. The external machine will be able to select specific shots and to initiate shots.

<b>CAUTION</b>
The external machine will not supply any voltage through any of the DB9 lines. It will only ground the received signals from Pins #7 and #8 to Pin #1 as needed.

### Ready Status Line

See FIG. 15 on page 24.

The Ready Status line tells the external machine when the shot controller is ready to receive signals. This line has two states: “High” and “Low.” When it is “High” there is 24V and when it is “Low” there is less than 5V.

The machine will send a 24V, or “High,” signal specifying it is ready to receive inputs when it is at the idle run screen.

The machine will send a less than 5V, or “Low,” signal specifying it is not ready to receive signals when it is dispensing, in one of the setup screens, or when an error code has been generated and has not yet been acknowledged on the shot controller.

## Dispense Request Line



See FIG. 15 on page 24.

The gun must be configured to “Tap” mode to use the dispense request line.

For the external machine to request a shot Pin #8: Dispense Request should be momentarily connected to Pin #1: External Machine Return Ground. This connection should last 150 milliseconds (mS) to 200 mS before being released.

If a Dispense Request signal is received when the Ready Status “High” signal is not being sent, the request is ignored.

## Shot Number or Sequence $n^{th}$ Shot Selection Line



See FIG. 15 on page 24.

The operating mode can only be changed using the HMI. When an external machine tries to select a shot, the machine will select a specific shot number if in Shot mode and will select a specific shot position within the selected sequence if in Sequence mode.

Selecting a shot is done in a manner similar to the Dispense Request line, where Pin #7 should be momentarily connected to Pin #1 using a semi-conductor based output.

Unlike the Dispense Request line where the line is grounded only once, Pin #7 is grounded to Pin #1 repeatedly. The period of time between Pin #7 being grounded should equal the period of time it is grounded, meaning the pattern followed should be  $x$  mS grounded,  $x$  mS ungrounded,  $x$  mS grounded,  $x$  mS ungrounded, etc. The allowable range for the period of time Pin #7 is ground/ungrounded is 10 to 100 milliseconds.

To request shot  $n$  or the  $n^{th}$  shot within the selected sequence, Pin #7 must be connected to and then disconnected from Pin #1  $n+1$  times. For example, to request shot 3, Pin #7 must be grounded four times.

After Pin #7 has been grounded  $n+1$  times, there must be a delay of four times the period Pin #7 was grounded for each of the  $n+1$  repetitions. For example, if Pin #7 was grounded for 15 milliseconds then ungrounded for 15 milliseconds and so on, there must be a delay of 60 milliseconds before activating the Dispense Request line.

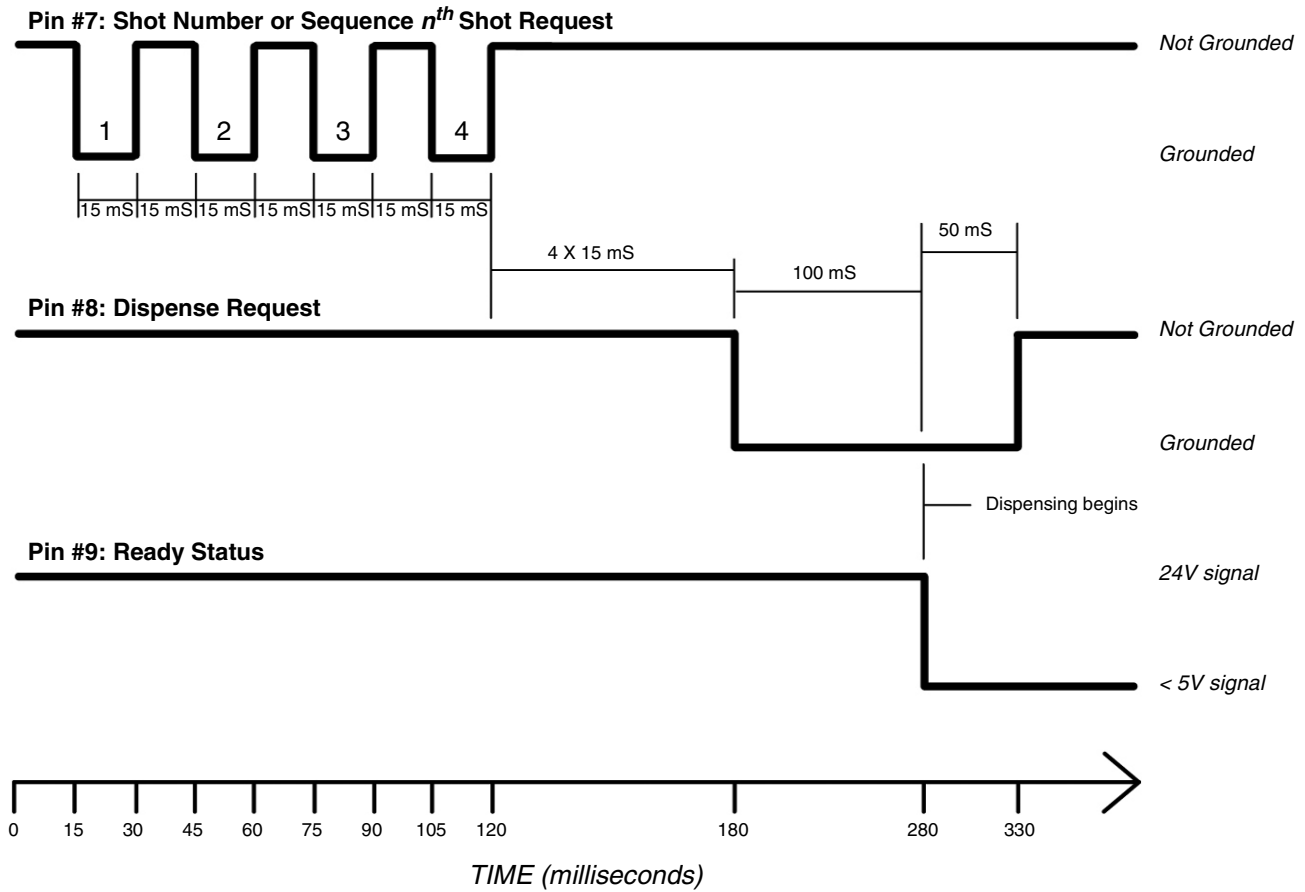



FIG. 15: Timing Diagram Example - Request and Dispense Shot #3



# Operation

 The AR Pour Gun and shot controller modify the hydraulic proportioner to pour instead of spray but all operation procedures from hydraulic proportioner operation manual 312062 are applicable.

## Startup

See hydraulic proportioner operation manual 312062.

## Change Operating Mode

Operating modes Shot (“Sh”) and Manual (“Mn”) will always be available and Sequence mode (“Sq-X”) will be available when one or more sequences are created by the user. See **Setup Screen #3: Shot Sequences** on page 17. To change the operating mode, hit the Mode Select key on the HMI until the desired operating mode is shown in the top left corner of the screen. Hit the top soft key to confirm the mode selection.

## Change Shot Number

 Only shots with non-zero volumes/weights can be selected.

To change the selected shot from the idle run screen, hit the up or down arrow keys. When the desired shot is selected, hit the top soft key to confirm the selection.

## Change Shot Volume/Weight

To change the defined shot volume or weight for the selected shot, first enter Run Screen Shot Editing mode by pressing and holding both the up and down arrow keys for three seconds. Use the up and down arrow keys to change the shot volume/weight then confirm the change when prompted.

If Run Screen Shot Editing is disabled, navigate to setup screen #2. Select the desired shot and use the up and down arrow keys change the shot volume/weight and confirm the change when prompted. See **Setup Screen #2: Shot Number Definitions** on page 17.

## Sequence Mode Options

### Restart Shot Sequence

In sequence mode, to restart a shot sequence from the first defined shot, press and hold the down arrow key for three seconds. When prompted, hit the top soft key to confirm restarting the sequence.

### Repeat/Skip Shot in Sequence

To repeat a shot, while at the idle run screen press the down arrow key and confirm when prompted. To skip a shot, while at the idle run screen press the up arrow key and confirm when prompted.

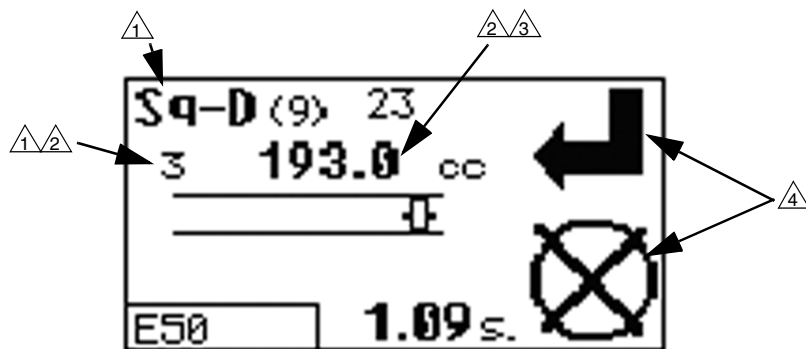

- ① When changing the operating mode or shot number, the item being changed will be highlighted
- ② During Run Screen Shot Editing, the shot quantity will be highlighted
- ③ A password may be required to edit this item
- ④ All changes must be confirmed or cancelled

**FIG. 16: Run Screen Shot Editing, Changing Operating Mode**

## Dispense Material



A shot can be initiated using either the gun trigger or the “Initiate Shot” button. See “Tap” and “Hold” Gun Modes on page 18.

## Maintenance Mode



When using Maintenance mode for anything other than shutting down the machine, close the material valves on the coupling block to avoid accidentally dispensing material. See AR Pour Gun manual 312888 for more information.

To perform cleaning, maintenance, or other work on the AR Pour Gun without error codes being generated, use Maintenance Mode. To enter Maintenance Mode, press and hold the bottom soft key for two seconds from the idle run screen.



When in Maintenance mode, the gun dispense valve can be opened and closed by pressing the top soft key twice or by press the gun trigger. Once the top soft key has been used to open or close the gun dispense valve, the gun trigger will be disabled. To regain the ability to open and close the gun using the trigger after using the top soft key, exit and re-enter Maintenance mode.

## Demo Mode

Demo mode is an alternate operating mode that is identical to standard operation but with a few exceptions. When in Demo mode, pouring, control of the gun and hydraulic proportioner, and Learn mode are all disabled. Also, settings and passwords saved in Demo mode are separate from settings saved in normal operation.

### Enter/Exit Demo mode

1. Remove then resupply power to the shot controller.
2. Within five seconds of the idle run screen appearing, press and hold both the bottom soft key and the down arrow key for six seconds.

 A “D” in the bottom, left corner of the HMI screen will be shown when in Demo mode.

## Hibernate Mode

The HMI will enter hibernate mode when idle for six minutes. To exit hibernate mode, press the up or down arrow key or trigger the gun.

If hibernate mode is exited by triggering the gun, the HMI will light to half brightness. To have the HMI display light to full brightness, press any key.

## Shutdown



 When shutting down the hydraulic proportioner, a small amount of material will be dispensed. Have a sheet of cardboard or other item ready to catch the dispensed material.

Enter Maintenance mode by pressing and holding the bottom soft key for two seconds then park the hydraulic proportioner by selecting the “PARK” button on the proportioner display. See hydraulic proportioner operation manual 312062 for more information.

# Pressure Relief Procedure

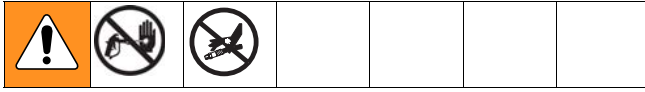

1. Relieve pressure in gun and perform gun shutdown procedure. See gun manual 312888.
2. Close gun fluid manifold valves A and B. See gun manual 312888.
3. Shut off feed pumps and agitator, if used.

4. Turn PRESSURE RELIEF/SPRAY valves (SA, SB) to PRESSURE RELIEF/CIRCULATION . Route fluid to waste containers or supply tanks. Ensure gauges drop to 0.

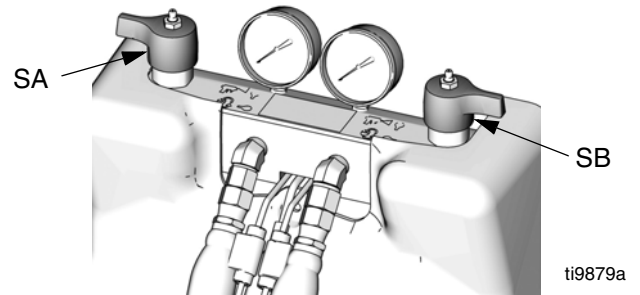

5. Engage gun safety lock. See gun manual 312888.
6. Disconnect gun air line and remove gun fluid manifold. See gun manual 312888.



# Troubleshooting

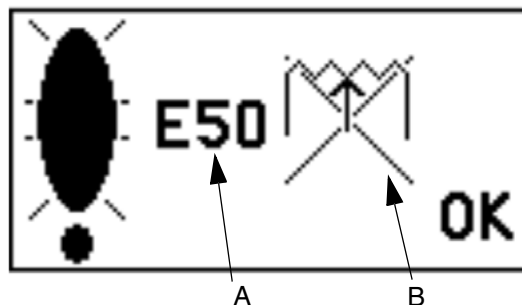

**Key:**  
 A Error Code  
 B Error Icon

FIG. 17: Error Alert Screen

## Error Codes

Error Code	Error Icon	Cause	Possible Solutions
E11		A key has been pressed for more than 30 seconds	<ul style="list-style-type: none"> <li>Check shot controller for stuck key</li> <li>Replace shot controller</li> </ul>
E50		Linear sensor fault, often caused if in Learn mode and piston position measured is outside the expected range	<ul style="list-style-type: none"> <li>Check wiring and replace as necessary</li> <li>Check linear sensor and replace as necessary                             <ul style="list-style-type: none"> <li>Learn mode will need to be used if linear sensor is replaced</li> </ul> </li> </ul>
E52		Dispense valve is stuck open or one of the material tanks is empty, leading to higher dispensed quantity than requested	<ul style="list-style-type: none"> <li>If dispense valve is stuck, the machine will automatically attempt to release it                             <ul style="list-style-type: none"> <li>The amount dispensed will be more than requested when this error occurs</li> </ul> </li> <li>Fill tank</li> <li>Adjust E52 alarm delay time from setup screen #4</li> </ul>
E53		A piston stroke has taken more than 10 seconds	<ul style="list-style-type: none"> <li>Verify that the gun safety is off</li> <li>Verify that the gun dispense valve is not stuck closed</li> <li>Verify adequate hydraulic or pneumatic pressure to machine</li> <li>Inspect for mechanical interference with the piston</li> <li>Verify correct power to the proportioner piston</li> </ul>
E54		This error code warns of the possibility of inconsistent shots but will allow the requested shot to occur. Shots requiring less than 1/8 of a full piston stroke will trigger this error code.	<ul style="list-style-type: none"> <li>Request a larger shot</li> <li>Verify that shot volume variation is ok</li> </ul>
E55		A shot has been requested that is above the maximum allowable amount.	<ul style="list-style-type: none"> <li>Request a smaller shot</li> </ul>
E56		Learn mode failed to learn piston travel range because: 1) Piston did not move during Learn mode 2) Linear sensor failure	<ul style="list-style-type: none"> <li>Repeat Learn mode</li> <li>Inspect the linear sensor and replace as necessary</li> </ul>

# Parts

Model, Series	Hydraulic Proportioner	Conversion Kit
255811, A	253725	24A024
255812, A	253726	24A024
255813, A	253727	24A024
255814, A	255400	24A024
255815, A	255401	24A024
255816, A	255402	24A024

## Hydraulic Proportioner

Refer to hydraulic proportioner repair manual 312063 for parts lists for each hydraulic proportioner.

## Conversion Kit 24A024

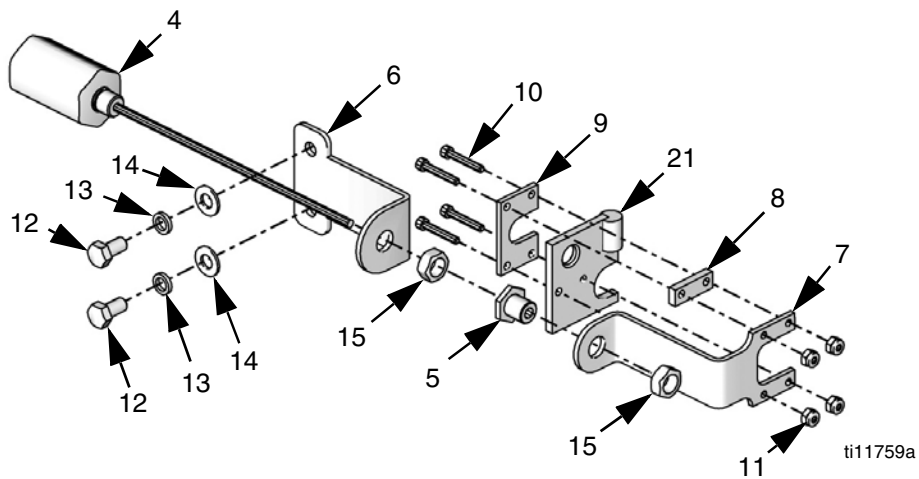
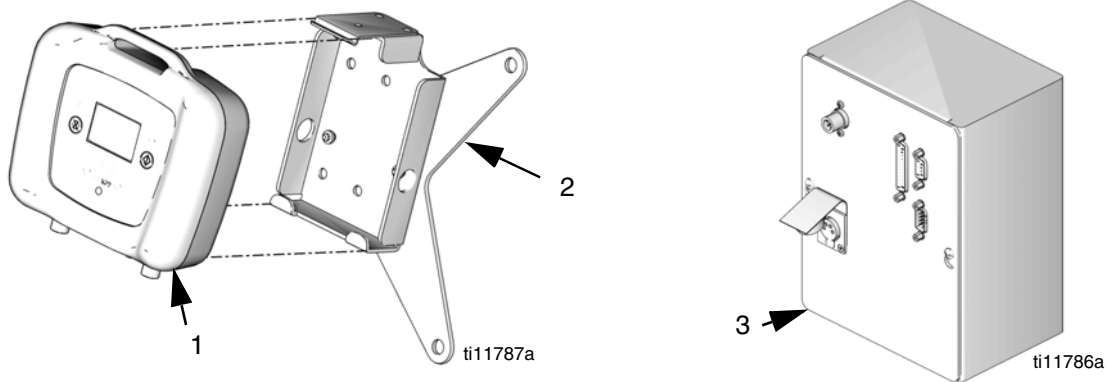

Ref	Part	Description	Qty
1	255817	PENDANT, shot meter	1
2	256217	KIT, bracket, pendant	1
3	256230	ENCLOSURE, electrical, assy	1
4	287839	SENSOR, assembly	1
5◆		KIT, holder, magnet	1
6◆		BRACKET, mounting, linear sensor	1
7◆		BRACKET, mounting, magnet	1
8◆		SPACER, bracket, magnet	1
9◆		PLATE, clamp, bracket, magnet	1
10◆		SCREW, cap, sch	4
11◆		NUT, lock, hex	4
12◆		SCREW, cap, hex hd	2
13◆		WASHER, lock, spring	2
14◆		WASHER, plain	2
15◆		NUT, head	2
16†	15T859	CABLE, assembly, DB25, 10 ft	1
17†	121003	CABLE, can, female / female 3.0m	1
18†	15T852	CABLE, assembly, DB9, 25 ft	1
19†	15T602	CABLE, assembly, DB9, 10 ft	1
20†◆		ADHESIVE, anaerobic	1
21◆		PLATE, activator, asm	1
22▲	189930	LABEL, caution	2

◆ *Parts included in Kit 24A071 which can be purchased separately.*

† *Parts not shown.*

▲ *Replacement Danger and Warning labels, tags, and cards are available at no cost.*





# Technical Data

Category	Data
Maximum Fluid Working Pressure	Models IPH-25 and IPH-40: 2000 psi (13.8 MPa, 138 bar)
Fluid:Oil Pressure Ratio	Model IPH-25: 1.91:1 Model IPH-40: 1.64:1
Fluid Inlets	Component A (ISO): 1/2 npt(f), 250 psi (1.75 MPa, 17.5 bar) maximum Component B (RES): 3/4 npt(f), 250 psi (1.75 MPa, 17.5 bar) maximum
Fluid Outlets	Component A (ISO): #8 JIC (3/4-16 unf), with #5 JIC adapter Component B (RES): #10 JIC (7/8-14 unf), with #6 JIC adapter
Fluid Circulation Ports	1/4 npsm(m), with plastic tubing, 250 psi (1.75 MPa, 17.5 bar) maximum
Maximum Fluid Temperature	190°F (88°C)
Maximum Output (10 weight oil at ambient temperature)	Model IPH-25: 22 lb/min (10 kg/min) (60 Hz) Model IPH-40: 50 lb/min (23 kg/min) (60 Hz)
Output per Cycle (A and B)	Model IPH-25: 0.063 gal. (0.23 liter) Model IPH-40: 0.076 gal. (0.29 liter)
Line Voltage Requirement	230V 1 phase and 230V 3 phase units: 195-264 Vac, 50/60 Hz 400V 3 phase units: 338-457 Vac, 50/60 Hz
Amperage Requirement	See <b>Models</b> , page 2.
Heater Power (A and B heaters total, no hose)	See <b>Models</b> , page 2.
Hydraulic reservoir capacity	3.5 gal. (13.6 liters)
Recommended hydraulic fluid	Citgo A/W Hydraulic Oil, ISO Grade 46
Sound power, per ISO 9614-2	90.2 dB(A)
Sound pressure, 1 m from equipment	82.6 dB(A)
Weight	All IPH-25 Models: 535 lb (243 kg) IPH-40 Models with 12.0 kW Heaters: 597 lb (271 kg) IPH-40 Models with 15.3 kW Heaters: 597 lb (271 kg)
Wetted Parts	Aluminum, stainless steel, zinc-plated carbon steel, brass, carbide, chrome, fluoroelastomer, PTFE, ultra-high molecular weight polyethylene, chemically resistant o-rings

All other brand names or marks are used for identification purposes and are trademarks of their respective owners.

# Graco Standard Warranty

Graco warrants all equipment referenced in this document which is manufactured by Graco and bearing its name to be free from defects in material and workmanship on the date of sale to the original purchaser for use. With the exception of any special, extended, or limited warranty published by Graco, Graco will, for a period of twelve months from the date of sale, repair or replace any part of the equipment determined by Graco to be defective. This warranty applies only when the equipment is installed, operated and maintained in accordance with Graco's written recommendations.

This warranty does not cover, and Graco shall not be liable for general wear and tear, or any malfunction, damage or wear caused by faulty installation, misapplication, abrasion, corrosion, inadequate or improper maintenance, negligence, accident, tampering, or substitution of non-Graco component parts. Nor shall Graco be liable for malfunction, damage or wear caused by the incompatibility of Graco equipment with structures, accessories, equipment or materials not supplied by Graco, or the improper design, manufacture, installation, operation or maintenance of structures, accessories, equipment or materials not supplied by Graco.

This warranty is conditioned upon the prepaid return of the equipment claimed to be defective to an authorized Graco distributor for verification of the claimed defect. If the claimed defect is verified, Graco will repair or replace free of charge any defective parts. The equipment will be returned to the original purchaser transportation prepaid. If inspection of the equipment does not disclose any defect in material or workmanship, repairs will be made at a reasonable charge, which charges may include the costs of parts, labor, and transportation.

**THIS WARRANTY IS EXCLUSIVE, AND IS IN LIEU OF ANY OTHER WARRANTIES, EXPRESS OR IMPLIED, INCLUDING BUT NOT LIMITED TO WARRANTY OF MERCHANTABILITY OR WARRANTY OF FITNESS FOR A PARTICULAR PURPOSE.**

Graco's sole obligation and buyer's sole remedy for any breach of warranty shall be as set forth above. The buyer agrees that no other remedy (including, but not limited to, incidental or consequential damages for lost profits, lost sales, injury to person or property, or any other incidental or consequential loss) shall be available. Any action for breach of warranty must be brought within two (2) years of the date of sale.

**GRACO MAKES NO WARRANTY, AND DISCLAIMS ALL IMPLIED WARRANTIES OF MERCHANTABILITY AND FITNESS FOR A PARTICULAR PURPOSE, IN CONNECTION WITH ACCESSORIES, EQUIPMENT, MATERIALS OR COMPONENTS SOLD BUT NOT MANUFACTURED BY GRACO.** These items sold, but not manufactured by Graco (such as electric motors, switches, hose, etc.), are subject to the warranty, if any, of their manufacturer. Graco will provide purchaser with reasonable assistance in making any claim for breach of these warranties.

In no event will Graco be liable for indirect, incidental, special or consequential damages resulting from Graco supplying equipment hereunder, or the furnishing, performance, or use of any products or other goods sold hereto, whether due to a breach of contract, breach of warranty, the negligence of Graco, or otherwise.

## **FOR GRACO CANADA CUSTOMERS**

The Parties acknowledge that they have required that the present document, as well as all documents, notices and legal proceedings entered into, given or instituted pursuant hereto or relating directly or indirectly hereto, be drawn up in English. Les parties reconnaissent avoir convenu que la rédaction du présente document sera en Anglais, ainsi que tous documents, avis et procédures judiciaires exécutés, donnés ou intentés, à la suite de ou en rapport, directement ou indirectement, avec les procédures concernées.

# Graco Information

**TO PLACE AN ORDER**, contact your Graco distributor or call to identify the nearest distributor.

**Phone:** 612-623-6921 **or Toll Free:** 1-800-328-0211 **Fax:** 612-378-3505

*All written and visual data contained in this document reflects the latest product information available at the time of publication.  
Graco reserves the right to make changes at any time without notice.*

*This manual contains English. MM 312878*

**Graco Headquarters:** Minneapolis  
**International Offices:** Belgium, China, Japan, Korea

**GRACO INC. P.O. BOX 1441 MINNEAPOLIS, MN 55440-1441**

Copyright 2008, Graco Inc. is registered to I.S. EN ISO 9001

[www.graco.com](http://www.graco.com)